

News Highlights – Issue 35:

[Jennic's New Single-chip Wireless Microcontroller Sets Benchmarks for ZigBee PRO and IEEE802.15.4 Wireless Mesh Networking](#)

[AverLogic Presents AL330B Digital LCD Display SOC](#)

[Schmartboard Makes Prototyping of Surface Mount Devices Easy](#)

[Embedded SBC PCs from AAEON Makes Product Development Easier](#)

[High Quality Antennas Now Available from EAD](#)

Jennic's New Single-chip Wireless Microcontroller Sets Benchmarks for ZigBee PRO and IEEE802.15.4 Wireless Mesh Networking



- *New benchmark for the lowest system operating current of any single-chip wireless microcontroller*
- *Integrates more memory than any other single-chip wireless microcontroller, having ample space for ZigBee PRO, either embedded together with an application, or as a co-processor*
- *Revolutionises location-based services for sensor networks with an innovative Time of Flight ranging engine*
- *Available as a standalone wireless controller chip or fully integrated module family for easy design-in and fast time to market*

Jennic, available through [GLYN High-Tech Distribution](#), announces a new single-chip 32-bit wireless microcontroller which sets new benchmarks for wireless networking communications based on the ZigBee PRO and IEEE802.15.4 standards. The combination of the lowest operating current consumption and

highest memory density of any single-chip wireless microcontroller, plus an innovative Time of Flight ranging engine, will enable the development of next-generation wireless mesh networks for battery-powered and data-rich applications.

The JN5148 32-bit wireless microcontroller achieves a system operating current consumption of 18mA when receiving, and 15mA transmitting at +3dBm, which is typically 35% lower than current solutions. With 128kB ROM, 128kB RAM and enhanced coding efficiency, the JN5148 has sufficient space for developers to integrate their embedded application software and the ZigBee PRO protocol stack into a single chip. It can also be used as a co-processor, enabling ZigBee PRO to be added easily and quickly to existing systems.

Programmable CPU clock speeds from 4 to 32MHz and the use of five separate power domains provide the ability to select low power or high performance up to 32 MIPS CPU operation for the JN5148 to be used across the full range of applications from low-power battery-backed networks to high I/O, processor intensive systems. A unique patent-pending Time of Flight ranging engine integrated into the device revolutionises location-based services for sensor networks by providing improved accuracy over conventional signal strength based systems with little incremental cost.

Jennic VP, Sales and Marketing, Tony Lucido, explains; "All Jennic products are designed to provide a fast route to high-performance wireless network development by combining field proven

stacks with innovative silicon features. A responsive support environment brings high-performance network development to designers with little or no experience of mesh networking, and helps experienced network designers to realise their most ambitious designs quickly and easily.” The JN5148 integrates a high-performance 32-bit RISC CPU core with mixed-signal peripherals and an IEEE802.15.4, 2.4GHz transceiver. The 98dB link budget and selectable high data-rate modes support indoor communication over distances of up to 50 meters, whilst 128-bit AES encryption ensures a high level of security.

Implementation requires very few additional devices; a crystal, discrete passives and a serial Flash memory, with a total bill of materials cost for external components of under 50c. The first version of the JN5148 is offered with Jennic’s ZigBee PRO stack and is supported by a comprehensive range of evaluation and development kits as well as reference designs, code examples and an online developer forum. In addition to the standalone wireless controller, the JN5148 is available in a fully integrated uFI module optimised for +2.5dBm standard power, or +20dBm high-power, providing a rapid and easy to implement route to product introduction.

Competitively priced, the JN5148 is sampling now to lead customers with full production planned at the end of the first half 2009.

For more details about Jennic JN5148 wireless microcontroller and JN5148-based modules, please send us an email at sales@glyn.com.au



AverLogic Presents AL330B Digital LCD Display SOC

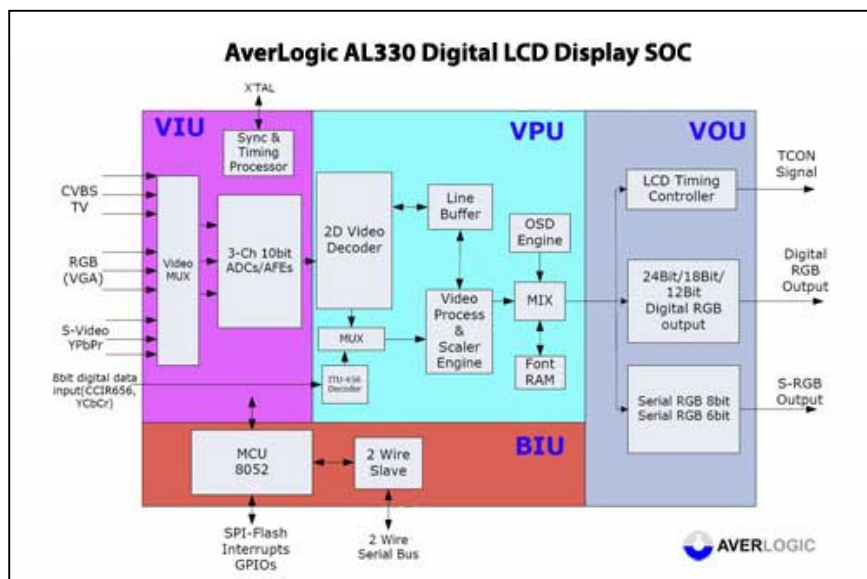

AverLogic, available through [GLYN High-Tech Distribution](#), is announcing the release of AL330B, a highly integrated Display System On Chip (SOC). AL330 contains a 3-Ch + 10-bit ADC, 2D Video Decoder, Deinterlacer, Scaler, Microcontroller, OSD, and TCON and can support small to medium Digital TFT-LCD Panels and small to medium Active Matrix OLED Display Devices.

The AL330B is a multi-channel analogue pre-processing circuit, which

includes source selection; anti-aliasing filter; ADC, ACC (Auto-Clamp Control) and AGC (Auto-Gain Control); CGC (Clock Generation Circuit); digital multi-standard decoder containing chrominance and luminance separation from an adaptive 2D comb filter; brightness, contrast, hue and saturation control circuit; programmable horizontal and vertical scaler; image and sharpness enhancement processing; On-Screen-Display; programmable TCON; and a digital RGB signal output etc.

Applications

- In-Car TV/GPS/Navigation & Entertainment Display Systems
- Video Door Phone, Baby Monitor, Digital Photo Frame etc.
- Small to Medium Multimedia TFT-LCD, AMOLED Display Monitor
- Portable TV/DTV (ATSC,DVB-T/-S)

Key Features

- CVBS, PC VGA and S-Video inputs with input video mux
- 3-channel 10-bit ADC and AFE
- 2D Video decoder
- Video Processor and Scaler engine
- 24-bit/18-bit/12-bit digital RGB output
- Serial RGB output
- Built-in 8052 MCU with 1Kbyte internal SRAM
- Dedicated UART & INT pins
- Supports SPI-Flash and ISP (In-System Programming) function
- 2 Wire Serial Bus

For more details about AverLogic AL330 Digital LCD Display SOC, please send us an email at sales@glyn.com.au



Schmartboard Makes Prototyping of Surface Mount Devices Easy

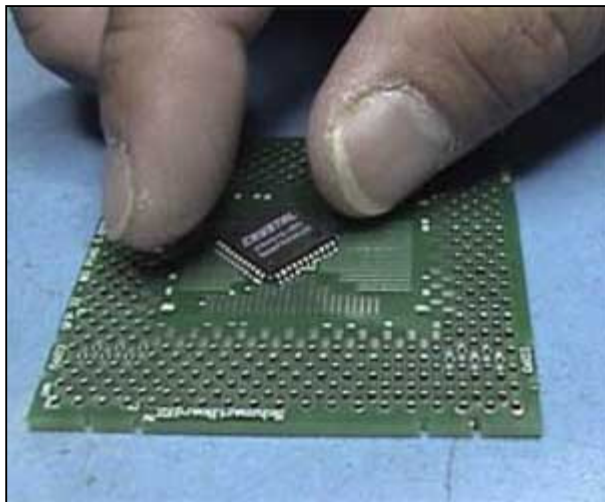

Has prototyping your electronic designs with a QFP, SOP, BGA, PLCC and other surface mount devices always been an expensive and cumbersome process, leading to slower time to market for your products?

SchmartBoard, a US company and available through [GLYN High-Tech Distribution](#), has developed PCBs which make prototyping of surface mount devices quite easy. SchmartBoard is the easiest electronic circuit prototyping system on the market.

Every company that designs a product involving electronics must first create a functional prototype. Hardware design engineers today either use prototype boards to test a circuit or they go straight to a custom printed circuit board (PCB) for the initial prototype. If they go straight to a custom PCB, the cost can be very high. Every time a change is made, they have to remake the custom PCB, which is both expensive and time consuming. A prototyping board on the other hand, can save the engineer valuable time and money by allowing changes to be made quickly and inexpensively, but if they do use a prototyping board they have had limitations. Prototyping boards have existed for a long time, but as surface mount components have become smaller and smaller, these boards have not kept up with the technology and have not remained a practical tool for many applications. SchmartBoard™ makes prototype boards useful again because they work with today's miniaturized components. Similar issues exist for universities that teach electronic engineering and for electronic hobbyists. The SchmartBoard™ system is the long-awaited answer to these issues.

Two problems impede people's ability to hand solder surface mount components. First, placing and holding the components in place correctly on the pad surface, and second, hand soldering in such small confined areas without creating short circuits.

SchmartBoard/ez's patent pending technology solves these issues in the following way. Unlike all other circuit boards, the solder mask is higher than the pads, not lower. What this does is create canals. The walls of the canal are made by the solder mask, and the floor of the canal is the pad surface. The legs of the IC fit into this canal, thus allowing easy hand placement of the chip legs onto the pads.

To solder the IC, one uses a fine tip soldering iron, but no additional solder is required. Using the soldering iron, one heats up the existing solder on the pads in each of the canals and pushes the

soldering iron from the lateral end of the canal to the medial end until the iron touches the chip's leg. The solder stays in the canal, thus assuring that no shorts are created. This is repeated for each canal that has a leg to be soldered. In the case of Ball Grid Arrays Integrated Circuits, the BGA is easily placed in the same manner as the ICs but a heat gun is used to heat up the existing solder on the pads instead of a soldering iron.

SchmartBoard/ez™ is so simple that a ten year old can pick up soldering iron for the first time, and hand-solder a .4mm IC, more quickly and flawlessly than the vast majority of engineer who aren't using SchmartBoard/ez™. Hand soldering surface mount components is now accessible to virtually anyone.

Designs can also be easily debugged and recycled by using a modular approach with SchmartBoard/ez™ where surface mount ICs can be soldered onto individual SchmartBoard/ez™ PCBs for SOP, QFP, PLCC, BGA and Through Hole ICs and then interconnected using SchmartBridge™ connectors. Developing prototypes using the SchmartBoard system becomes similar to using Lego blocks where complicated prototypes can be built and tested much easier by interconnecting fully tested and debugged SchmartBoard modules.

For more details about SchmartBoard products, please send us an email at sales@glyn.com.au



Embedded SBC PCs from AAEON Makes Product Development Easier

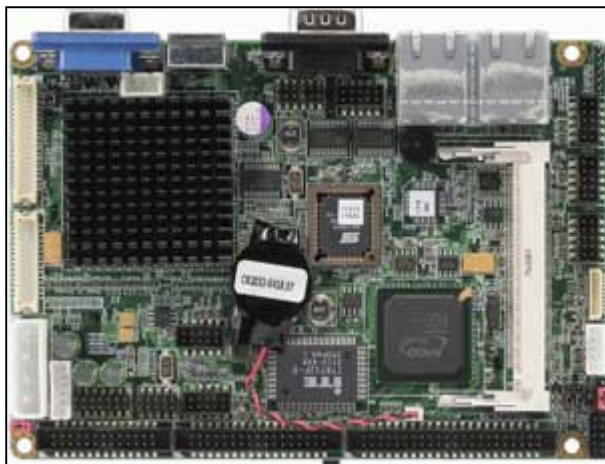

There are many real world applications where the simplest and best solution is sometimes the obvious one. Why develop a custom electronics circuitry and reinvent the wheel when a simple PC can do the job with minimal development time and cost?

Embedded Single Board Computers from AAEON and available through [GLYN High-Tech Distribution](#) make product development a breeze. AAEON's embedded computing solutions come in Sub-Compact 3.5" Form Factor, Boxed Industrial PC Systems or Panel PC Systems with integrated display.

Typical applications for embedded PCs include:

- Portable POS

- Building / Factory Automation
- Compact Information System
- Panel PC
- Gaming Machine
- Transportation
- Medical Machine & KIOSK

The Sub-Compact SBCs are available with Intel or AMD CPUs, fanless, and single +5V only or +12V only versions. Various RAM sizes and onboard peripheral options like LAN, USB and COM ports are available.

For more information on AAEON's Embedded Computing products, please send us an email at sales@glyn.com.au





High Quality Antennas Now Available from EAD

GLYN High-Tech Distribution is now offering high quality 2.4GHz antennas from UK-based EAD which is ideal for Bluetooth, ZigBee/IEEE 802.15.4 and Wi-Fi applications. 2.4GHz antennas include the Stubby, Knuckle and Blade models.

The Stubby antenna with SMA male connector measures 32x8mm (incl. SMA) for the straight model and 34.5x8mm (excl. SMA) for the right-angle model and has 0 dBi peak gain.

The Knuckle antenna with SMA male connector measures 138 x 13 mm (length x diameter) and has 2 dBi peak gain.

The Blade antenna with RG174 cable and MMCX connector measures 72 x 19 x 7mm (max) and has 2 dBi peak gain, with 10W power rating making it ideal for telematics/telemetry applications.

GSM and GPS antennas from EAD are also available.

GLYN also offers non-EAD antennas and interface cables to suit varying customer needs.

For more details about the EAD and other GSM, 3G, GPS and 2.4GHz antennas, please send us an email at sales@glyn.com.au



For more information about GLYN Ltd products, please visit our website at www.glyn.com.au

To **unsubscribe** to this newsletter, click [here](#).

GLYN Ltd (Australia and New Zealand) is a high-tech solutions provider and the exclusive distributor for a select range of semiconductors and electronic component manufacturers from Japan, Europe, USA and Taiwan. We are the sister company of GLYN GmbH (Germany) which has sales offices throughout Central Europe, Scandinavia and the UK.

GLYN represents some of the major brands in the industry such as Mitsubishi Electric, Fujitsu, Mitsubishi Materials, Micronas, Telit, Jennic, Maxwell, Fastrax, Cyan, FTDI, Bluegiga, Yitran, Sierra Monolithics, Isahaya Semiconductors, AUO, Univision and CMEL OLED and EDT LCD displays. Through our extensive network of suppliers we can also source those hard to find or obsolete items from a range of the world's premier semiconductor suppliers including Renesas, Toshiba, NEC, NEC-Tokin, Sony, Seiko Instruments, Yamaichi, Suyin, ICSI, Wavecom, Infineon, and Displaytech.